

Accessories

CHISELS FOR FCH-20

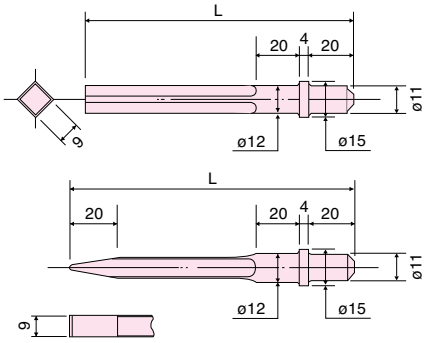

Type	AC No.	Size
		L mm
Blank	G-1-1	125
	G-1-2	155
	G-1-3	200
	G-1-4	250
	G-1-5	300
Flat	G-2-1	130
	G-2-2	155
	G-2-3	200
	G-2-4	250
	G-2-5	300

TIPPED CHISELS FOR FCH-20

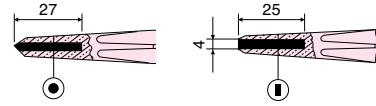

Type	AC No.	Overall Length	Remark
		mm	
Point	S-1	120	Standard
	S-3	160	Small Point
	S-2	120	Standard
Flat	S-2	120	Standard
	S-4-1	160	Small Flat

BUSHING CHISELS FOR FCH-20



AC No.	Tip Size		
	Point	I x w x L	
TWH-0006	4	2.5 x 2.5 x 5	

CHISELS FOR FCH-20F, 25 AND 25B

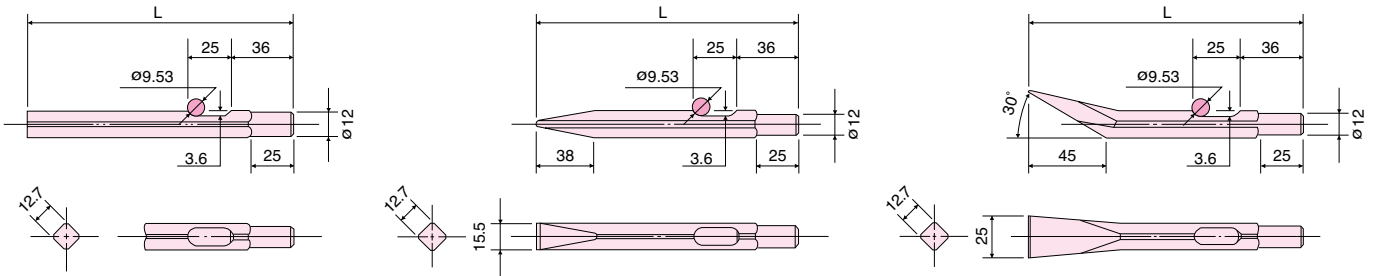

Type	AC No.	Size
		L mm
Blank	F-1-1	140
	F-1-2	155
	F-1-3	200
	F-1-4	250
	F-1-5	300

Type	AC No.	Size
		L mm
Flat	F-2-2	155
	F-2-3	200
	F-2-4	250
	F-2-5	300
	F-2-6	350
	F-2-7	400

Type	AC No.	Size
		L mm
Flux	F-3-2	155
	F-3-3	200
	F-3-4	250
	F-3-5	300
	F-3-6	350
	F-3-7	400

BUSHING CHISELS FOR FCH-20F, 25 AND 25B



AC No.	Tip Size		
	Point	I x w x L	
TWH-0007	4	6 x 6 x 12	
TWH-0003	9	5 x 5 x 15	
TWH-0002	16	4 x 4 x 16	
TWH-0004	25	4.5 x 4.5 x 22.5	

CHISELS FOR FRH SERIES

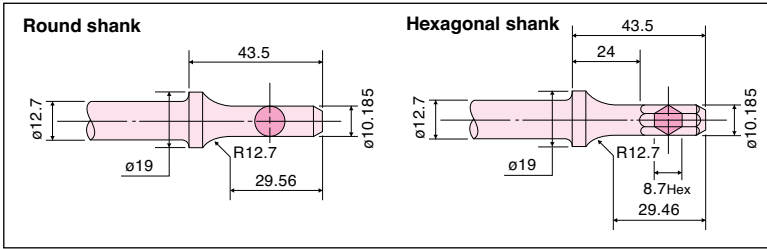

Index No.	AC No.		Part Name
	Round	Hexagonal	
808	WA-808	WA-808H	Muffler Cutter
809	WA-809	WA-809H	Double Edge Panel Cutter
810	WA-810	WA-810H	Flat Chisel
812	WA-812	WA-812H	Taper Punch
813	WA-813	WA-813H	Rivet Cutter
814	WA-814	WA-814H	Blank Chisel
815	WA-815	WA-815H	Spot Weld Breaker

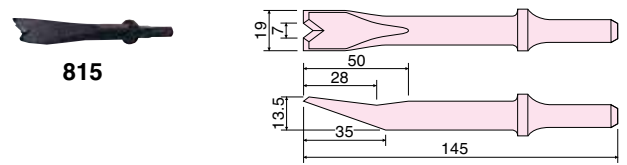
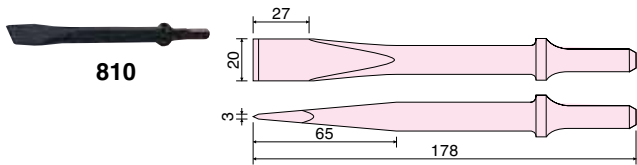
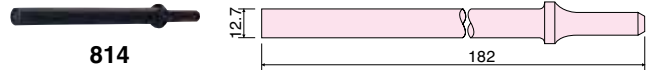
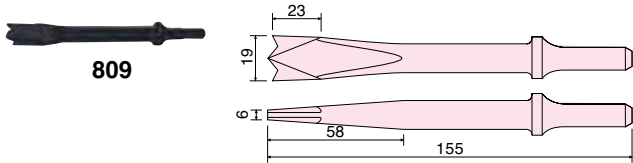
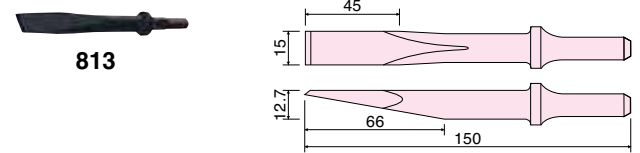
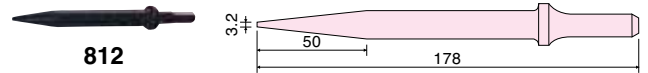
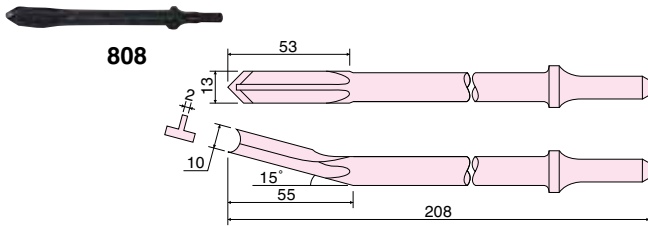

Accessories

RETAINER FOR FRH SERIES



Holder Spring Holder Spring (B)

Part No.			Part Name
FC-01SA	FRH-3, 6	FRH-6A	
H-043715-00	H-019715-00	H-024715-00	Holder Spring
H-043719-00	H-019719-00	H-024719-01	Holder Spring (B)

RIVET SNAPS FOR FRH SERIES

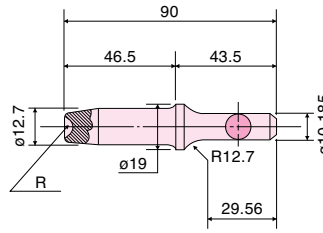

AC No.	R Size	Rivet Size
	mm	mm
SNAP-3	3.0	3
SNAP-4	3.7	4
SNAP-5	4.8	5
SNAP-6	5.1	6

RUBBER BUTTS FOR FR-SERIES



AC No.	Size			Model
	D	d	H	
	mm	mm	mm	
R-1	51	11.8	60	FR-18B, 18L
R-1-1	41	12.7	47	FR-18B, 18L
R-2	51	13.75	60	FR-22B, 22L
R-3	67	17.25	80	FR-25B, 25L
R-4	75	18.75	92	FR-32