

MODULAR POWER PACKS WITH PETROL ENGINE 700 BAR

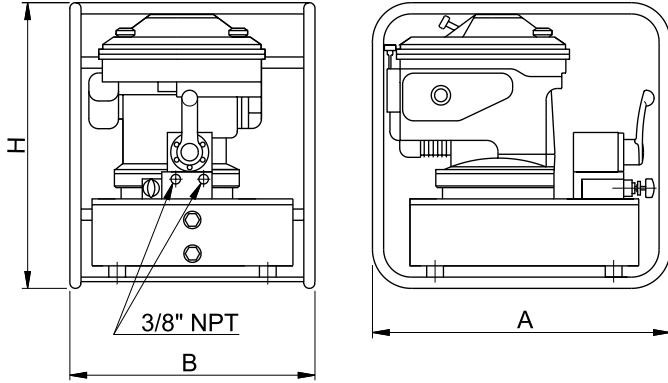

- Reservoir capacity **10 - 40 l**
- Delivery at 700 bar **0,9 - 1,8 l/min**
- Power rating **3,6 kW**
- Max pressure **700 bar**
- Consumption **1,28 l/h with full load**
0,9 l/h at 75%

DIMENSIONS

Reservoir capacity litres	Usable oil volume litres	Dimensions mm		
		A	B	H
10 low	7,7	555	440	500
20	17,7			628
40	35,8	510	660	580

Follow our safety instructions,
see useful pages

p. 126

OPERATING CHARACTERISTICS

MODEL	Oil delivery		Pressure		Engine	
	1 st Stage	2 st Stage	1 st Stage	2 st Stage	Power	Speed
	l/min	l/min	bar	bar	kW	rpm
MSD	1,8	0,9	100	700	4,4	3000
MSE	9,4		85			
MSF	-	1,8	-			
MSG	4,7		85			

DELIVERY DIAGRAM

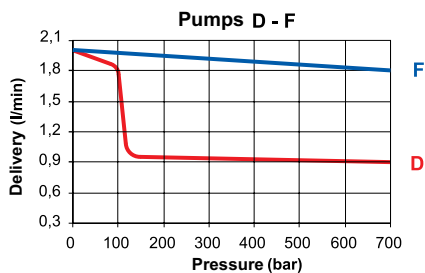

DELIVERY DIAGRAM

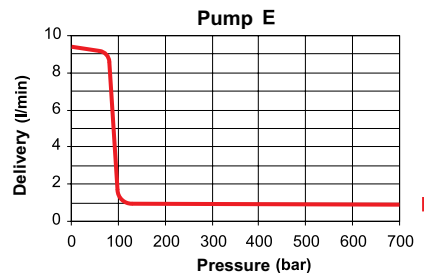

DELIVERY DIAGRAM

