

RUSTFRIE PNEUMATISKE SYLINDERE

Sylindere basert på DIN/ISO 6431

Sylinder diameter: Ø32 - Ø63

Med magnet for avkjenning og justerbar endeslagsdemping

Oppbygning av artikkelnummer:

U - Syl. dia. - slaglengde - forgavl - bakgavl

Eks.: Sylinder med glatt forgavl og bakgavel med svingøye
Ø63x160 = U063 0160 1116

Alle gavlene på denne side kan fritt kombineres med VDMA gavler

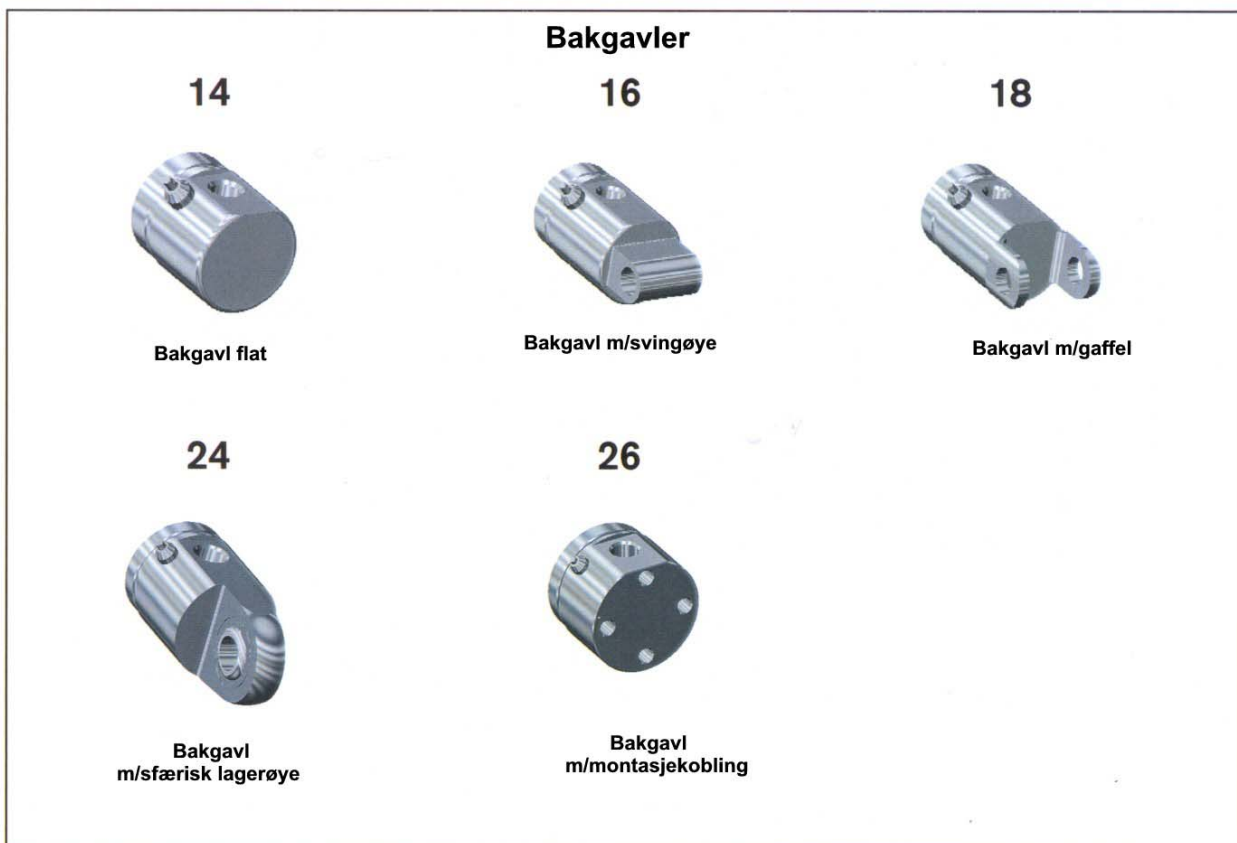
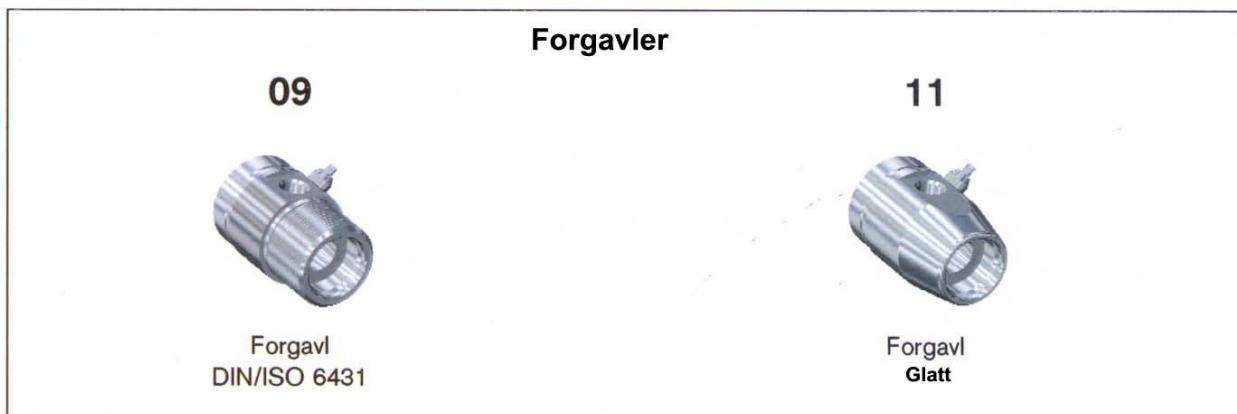

RUSTFRIE PNEUMATISKE SYLINDERE

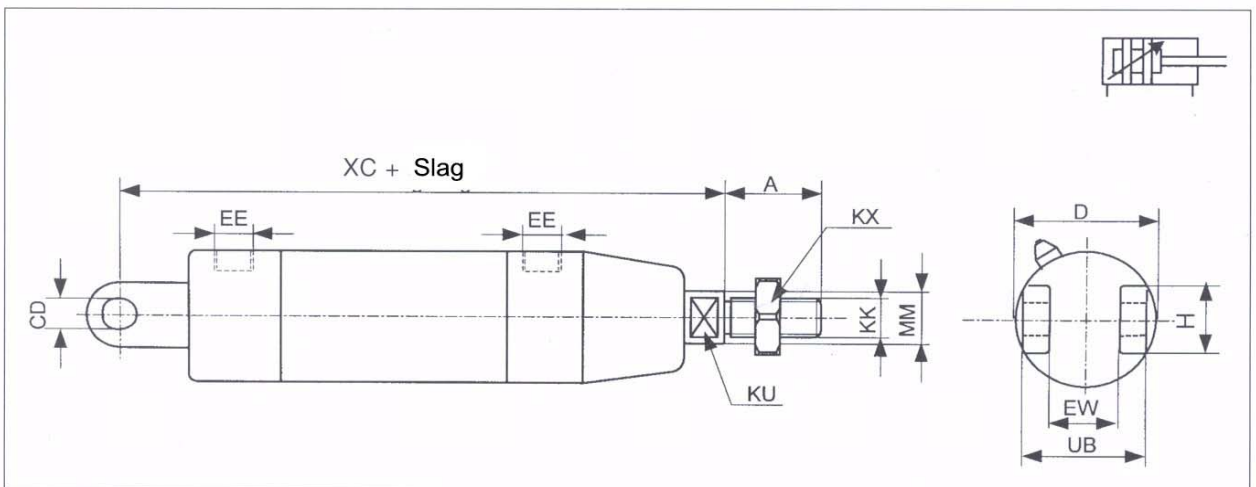
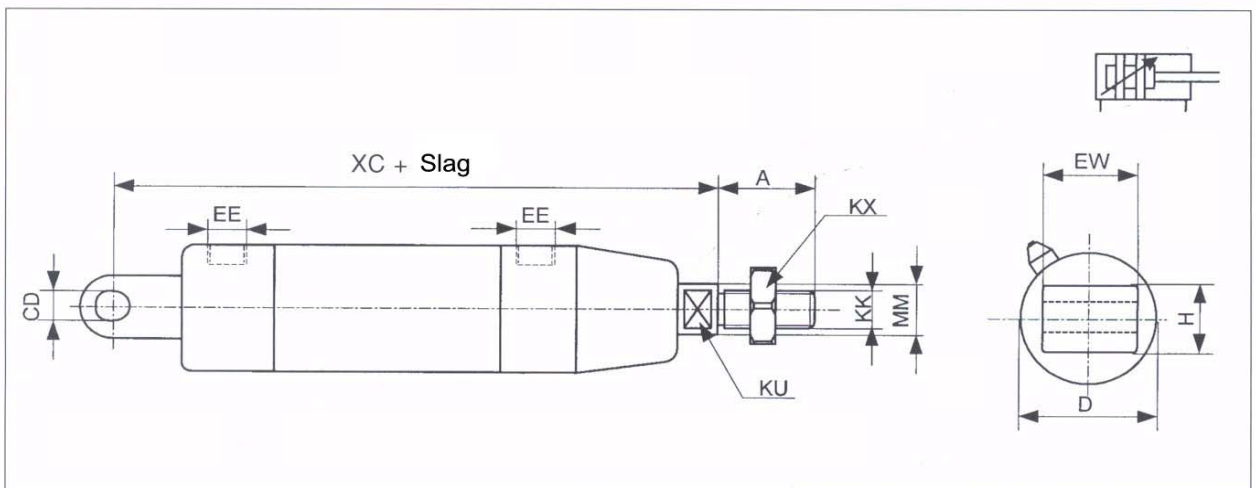
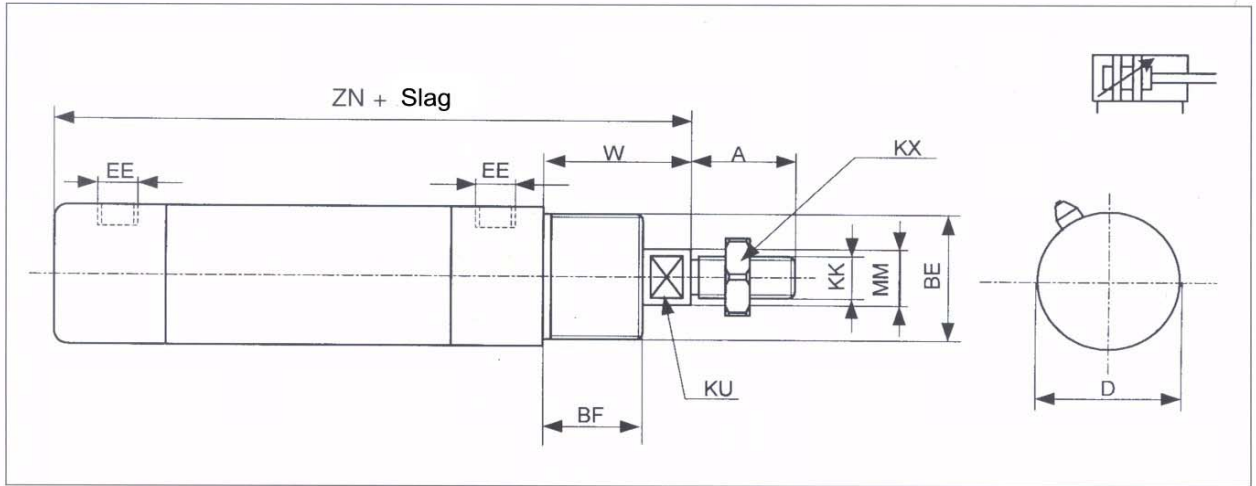

Syl. dia.	A	BE	BF	CD	D	EE	EW	H	KK	KU	KX	MM	UB	W	XC	ZH
32	22	M30x1,50	22	10	33,6	G1/8"	26	15	M10x1,25	10	17	Ø12	35	32	142	125
40	24	M36x1,50	25	12	41,6	G1/4"	28	20	M12x1,25	13	19	Ø16	40	37	160	138
50	32	M42x1,50	28	12	52,4	G1/4"	32	20	M16x1,50	17	24	Ø20	50	40	170	147
63	32	M42x1,50	27	16	65,4	G3/8"	40	22	M16x1,50	17	24	Ø20	60	39	190	161